

# ***FITTING INSTRUCTIONS***

**ATTENTION:** before carrying out any work on the exhaust, check that its surface has cooled so that it will not damage components, which are not heat-resistant (such as fairing, hoses, rubber sleeves, etc.), or the operator.

- 1.** Remove the OE silencer(s)
- 2.** Check that the mating surfaces are in good clean condition, slide the link pipe on to the original header, taking care not to damage the graphite gasket (if supplied) which should replace the OE gasket. Partially tighten the securing strap to allow a degree of further adjustment.
- 3.** Slide the Leovince SBK silencer onto the link pipe, check the alignment of the mounting eyes for the springs and the alignment of the exhaust outlet to the rear of the silencer, and then link the parts together with the springs provided
- 4.** Fit the carbon strap(s) to the silencer(s); mount spacers, washers and brackets (if any) as shown on the drawing and then secure by tightening nuts and bolts.
- 5.** Tighten the various clamps which join the Leovince SBK link pipe(s) to the OE exhaust headers.
- 6.** Start the engine, wait a few minutes until it reaches operating temperature, and check that there are no gas leaks.

**IMPORTANT:** During the first km of running, the exhaust system needs breaking-in; therefore, slight gas leakage might occur. After approximately 100 Km, check all the fasteners.

## **ADJUSTMENT:**

This silencer has been developed by Leovince on an electronic test bed using a machine in perfect condition, and in standard trim.

## **MAINTENANCE:**

From time to time, check all the brackets and fasteners, which could be affected by use (sound-deadening material, seals and other rubber parts) and replace them periodically. The silencer may be cleaned using gasoline, diesel oil or alcohol. Absolutely avoid the use of any kind of solvent.

It is normal for there to be some discolouration of the silencer, which is the result of heat and the nature of the materials used.

**IT IS FORBIDDEN** to modify silencers. Whatever form this may take, SITO GRUPPO INDUSTRIALE declines any responsibility for defects, problems, or malfunction, arising from the use of any product which has been modified or tampered with.

**WE SUGGEST THE FITTING TO BE MADE BY PROFESSIONALS**

# TECHNICAL DRAWING

**I – ATTENZIONE !** Per utilizzare lo scarico "LeoVince" in presenza di targhe di dimensioni superiori a 17cm x 17cm è necessario sostituire il tappo del silenziatore con quello fornito in confezione.

**GB – WARNING !** When the LeoVince exhaust is fitted on bikes with number plates which dimensions are bigger than 17cm. x 17cm., it is necessary to replace the dB-killer of the silencer with the one supplied in the packaging.

**F – ATTENTION !** Pour l'installation de l'échappement "LeoVince" sur les motos dont la plaque d'immatriculation mesure plus de 17cm x 17cm, remplacer le reducteur de bruit monté de série par celui qui est fourni dans le carton.

**D – ACHTUNG !** Wenn der LeoVince Auspuff an Motorrädern mit einem Nummernschild, das größer als 17 cm x 17 cm ist, montiert wird, ist es notwendig den im Schalldämpfer montierten dB-Killer mit dem im Karton mitgelieferten dB-Killer zu ersetzen.

**E – ATENCIÓN !** En el proceso de montaje del escape "LeoVince" para las motos que llevan la matricula con dimensiones superiores a 17cm x 17cm, se debe sustituir el reductor de ruido montado de serie por el que viene en la caja.

VISTA DA "AA"

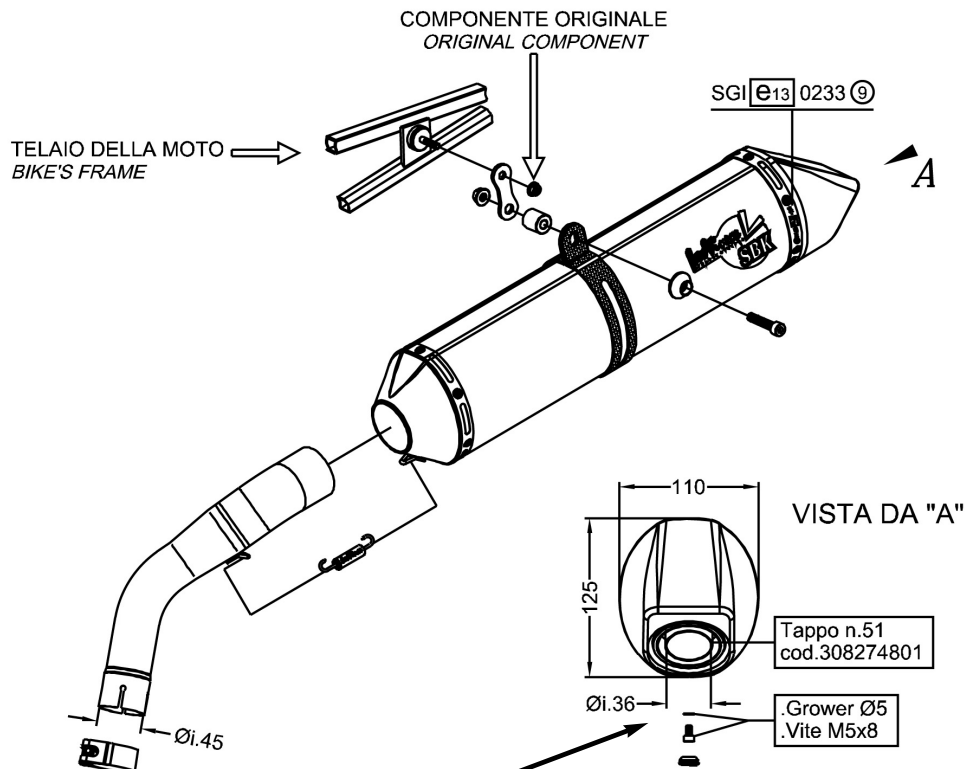
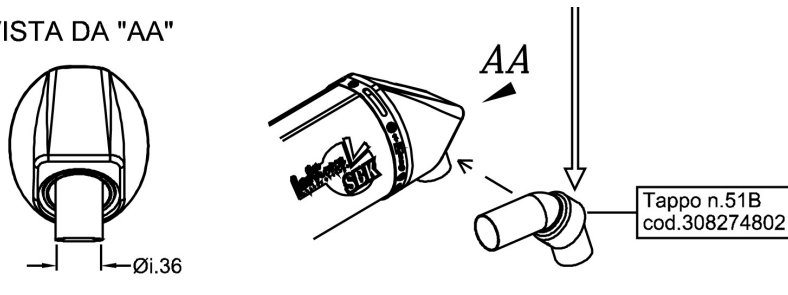

**I – ATTENZIONE !** Non rimuovere il dB-killer!

Il portatarga e la targa stessa potrebbero venire danneggiati dai gas di scarico!

**GB – WARNING !** Don't remove the dB-killer!

The number plate holder and the number plate itself could be damaged from the exhaust gas!

**F – ATTENTION !** Ne pas retirer le reducteur de bruit!

Le support de plaque ainsi que la plaque pourraient être brûlés par les gaz d'échappement!

**D – ACHTUNG !** Entfernen Sie nicht den dB-Killer!

Der Kennzeichenhalter und das Nummernschild könnten durch die austretenden Abgase beschädigt werden!

**E – ATENCIÓN !** No quitar el reductor de ruido!

El portamaticulas y tambien la matricula podrian ser quemados por los gases de escape!